

## Model W4000

Power/RPM	kW/RPM (hp/RPM)	Maximum rated input	kW (hp)	Ratio	Maximum input RPM
0,510 (0,693)		918 (1231)		3,077	1800
0,451 (0,613)		902 (1210)		3,474	2000
0,399 (0,543)		918 (1231)		3,923	2300
0,368 (0,500)		957 (1283)		4,258	2600
0,339 (0,461)		949 (1273)		4,625	2800
0,298 (0,406)		834 (1118)		5,248	
0,262 (0,356)		734 (984)		5,978	
Dry weight	kg(lb)	1270 (2800)			
SAE bell		#0,#00			
Type		Vertical offset			
Kinematics		Reversible or Non-Reversible ( Engine-Wise or Counter-Engine-Wise )			

## Description

- Robust design and easy onboard maintenance.
- Robust design also withstands continuous duty in workboat, dredger applications.
- Fully works tested, reliable and simple to install.
- Reverse reduction marine transmission with hydraulically actuated multi-disc clutches.
- Case hardened and precisely ground gear teeth for long life and smooth running.
- Robust cast iron casing for direct or remote mounting.
- Emergency "get home" capability.
- Design, manufacture and quality control standards comply with ISO.
- Suitable for twin installation with 100% rated power in ahead and astern condition.

Sample Powers kW (hp)

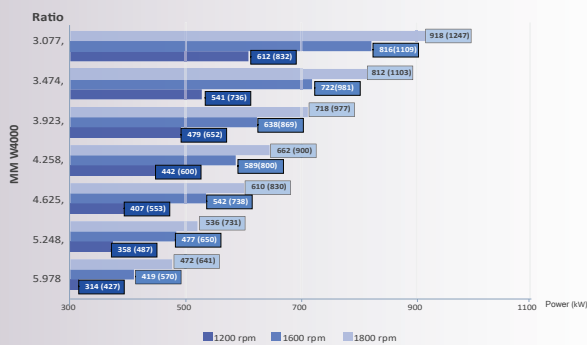

## Standard Equipment

- Oil cooler complete with fittings and flexible hoses.
- Integrated Brackets.
- Free Standing.
- Lube Oil Pump.

## Option

- Engine-matched torsional coupling.
- Propeller shaft flange and coupling bolt set.
- Classification by all major Classification Societies on request.
- PTO (live or clutchable).
- Electric trolling valve for slow-speed drive.
- Shaft brake.
- Electric clutch control.

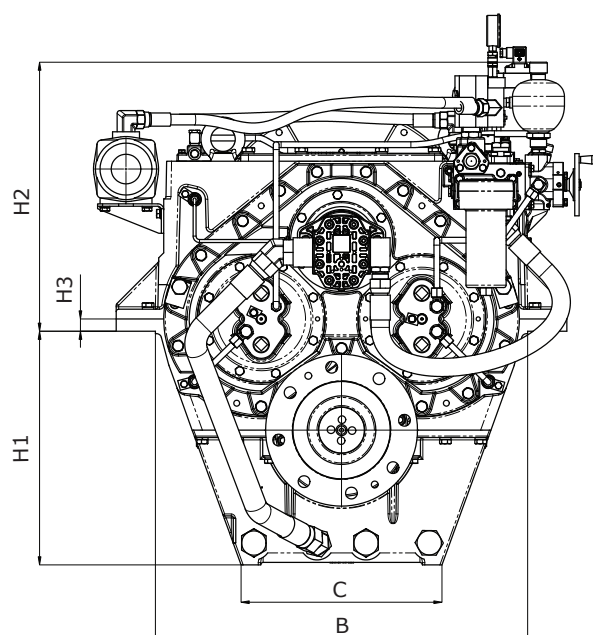
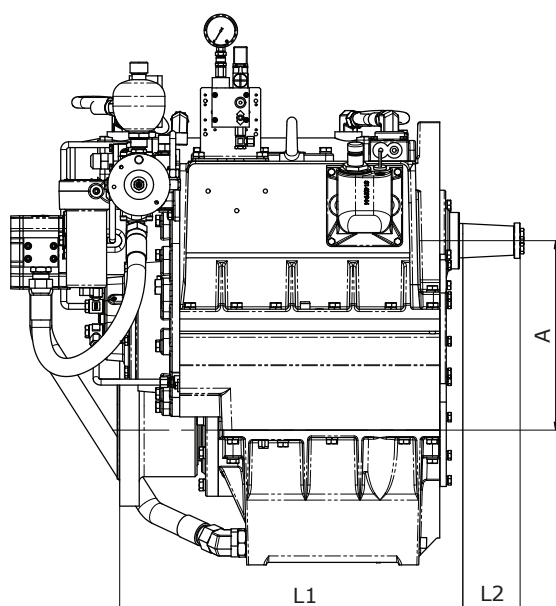

Model	Bell Housing SAE N°	A	B	C	H1	H2	H3	L1	L2	Dry Weight kg(lb)
		Dimensions in mm								
W4000	#0,#00	387	760	410	477	542	202	700	105	1270 (2800)

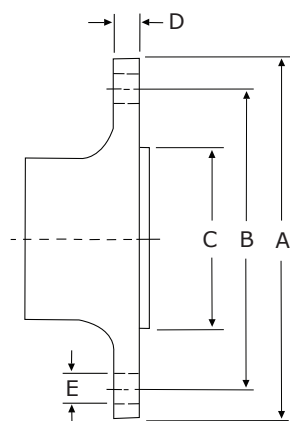

Output Coupling dimension										
A		B		C		D		Bolt Holes		
mm	inch	mm	inch	mm	inch	mm	inch	No.	Diameter (E)	
									mm	in
310	12,2	260	10,2	200	7,9	40	1,6	8	24	0,94

Masson Marine products are available all over the world through our network of dealers

Dealer:



[www.masson-marine.com](http://www.masson-marine.com)

contact@masson-marine.com

5 rue Henri Cavallier

89100 Saint Denis les Sens - France

