

Model		W1950			
Power/RPM	kW/RPM (hp/RPM)	Maximum rated input	kW (hp)	Ratio	Maximum input RPM
0,210 (0,282)		588 (789)		4,103	2800
				4,481	
				4,920	
				5,727	
0,193 (0,259)		540 (725)		6,400	
0,172 (0,231)		482 (646)		7,222	
0,157 (0,211)		440 (590)		7,706	
Dry weight	kg(lb)	720 (1593)			
SAE bell	#0, #1				
Type	Vertical offset				
Kinematics	Non Reversible, Engine Wise and Counter Engine Wise				

Description

- Robust design and easy onboard maintenance.
- Robust design also withstands continuous duty in workboat, dredger applications.
- Fully works tested, reliable and simple to install.
- Reverse reduction marine transmission with hydraulically actuated multi-disc clutches.
- Case hardened and precisely ground gear teeth for long life and smooth running.
- Robust cast iron casing for direct or remote mounting.
- Emergency "get home" capability.
- Design, manufacture and quality control standards comply with ISO.
- Suitable for twin installation with 100% rated power in ahead and astern condition.

Sample Powers kW (hp)

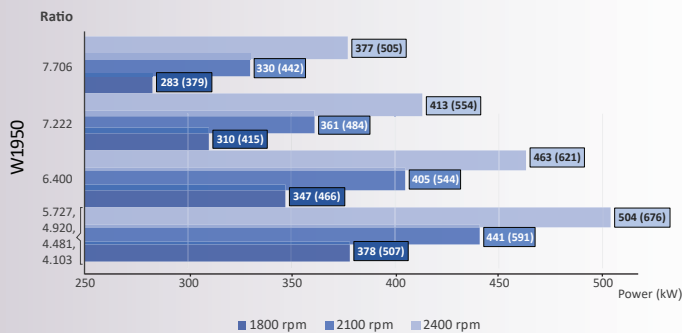

Standard Equipment

- Oil cooler complete with fittings and flexible hoses.
- Integrated Brackets.
- Free Standing.
- Lube Oil Pump.

Option

- Engine-matched torsional coupling.
- Propeller shaft flange and coupling bolt set.
- Classification by all major Classification Societies on request.
- PTO (live or clutchable).
- Electric trolling valve for slow-speed drive.
- Shaft brake.
- Electric clutch control.

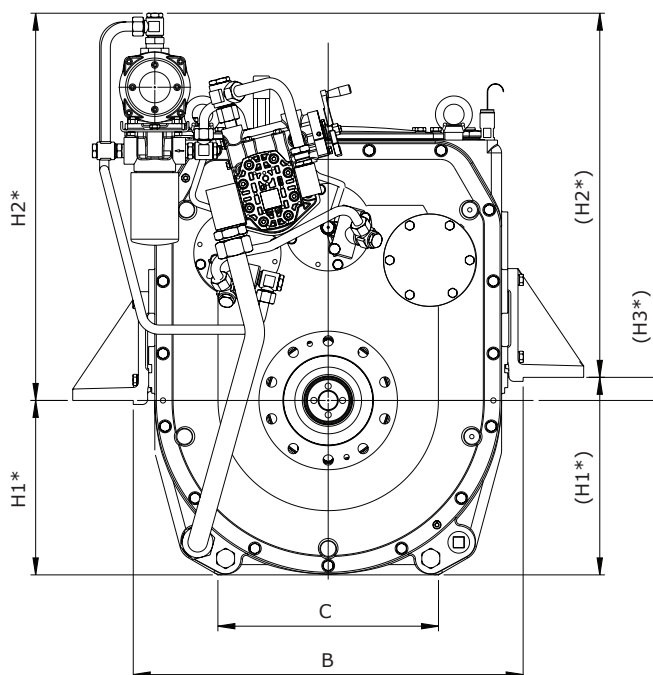
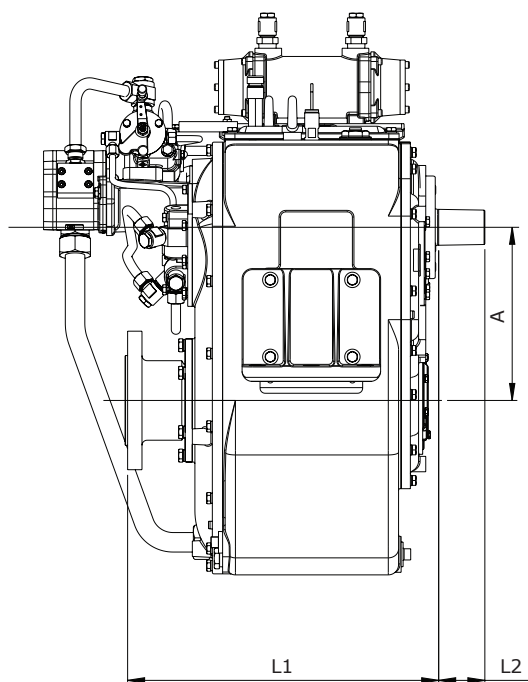

Model	Bell housing	A	B	C	H1	H2	H3	L1	L2	Dry Weight kg (lb)
		Dimensions in mm								
W1950	#0, #1	338	760	430	340(385)	755(710)	0(45)	607	90	720 (1593)

* Various choice of brackets (H1, H2, and H3 dimensions above are for the standard bracket.)

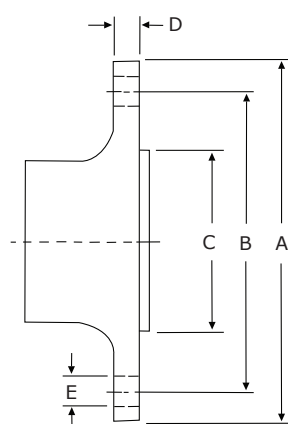

Output Coupling dimension

A		B		C		D		Bolt Holes		
mm	inch	mm	inch	mm	inch	mm	inch	No.	Diameter (E)	
									mm	in
270	10,6	232	9,1	175	6,9	28	1,1	10	20	0,8

Masson Marine products are available all over the world through our network of dealers

Dealer:



www.masson-marine.com



contact@masson-marine.com

5 rue Henri Cavallier

89100 Saint Denis les Sens - France

